

178AM1

CHEVROLET CORSA 1.4 / 1.6cc - MOTOR
C14NV/NZ - E16SE/NE/NZ - C16LZ/NV

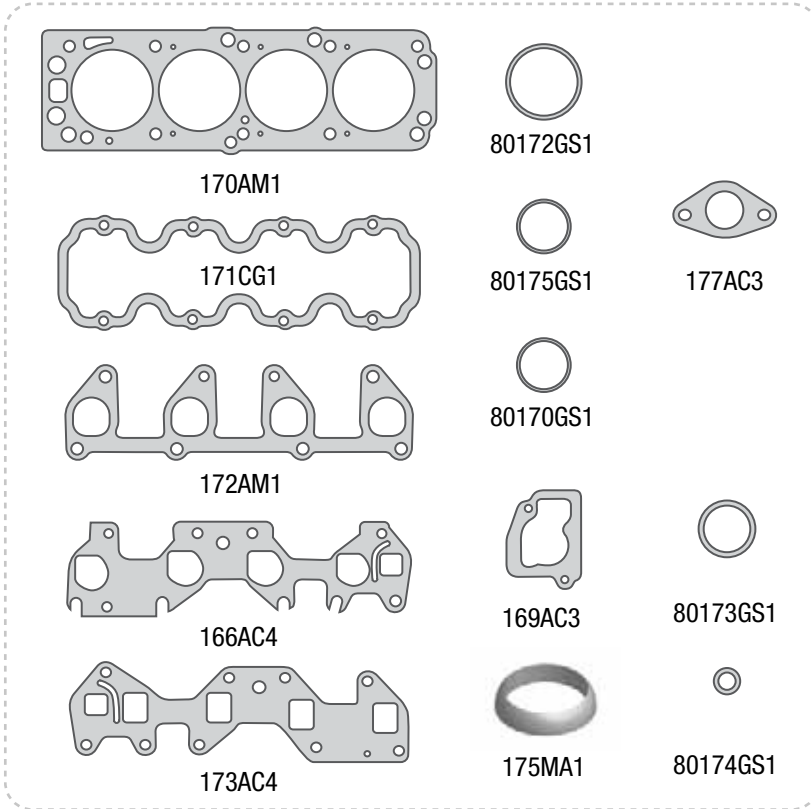

179AM1

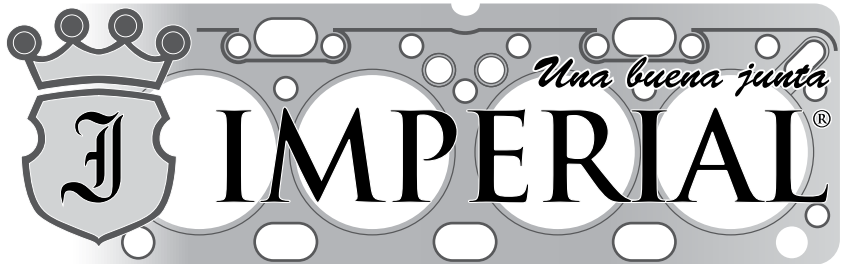
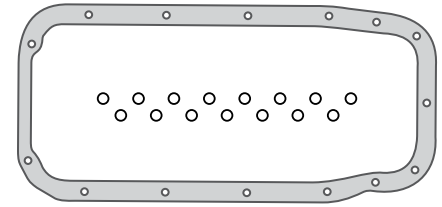

174CG1

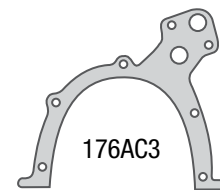

176AC3



80171GS1

*Se incluye juego de ARANDELAS METÁLICAS

Nº Imperial	Nº Original	Descripción	Nº Imperial	Nº Original	Descripción
170AM1		JUNTA TAPA DE CILINDROS			
171CG1		JUNTA TAPA DE VALVULAS			
174CG1		JUNTA PARA CARTER			
166AC4		JUNTA MULTIPLE ADMISION - EFI			
172AM1		JUNTA MULTIPLE DE ESCAPE			
173AC4		JUNTA MULTIPLE ADMISION - MPFI			
175MA1		JUNTA SALIDA DE ESCAPE ANILLO			
169AC3		JUNTA BASE INYECCIÓN MULTIPUNTO			
176AC3		JUNTA FRENTE MOTOR BOMBA DE ACEITE			
177AC3		JUNTA SALIDA DE GASES			
80170GS1		ORING TERMOSTATO CON RANURA INTERIOR			
80171GS1		ORING BOMBA DE AGUA			
80172GS1		ORING CARCAZA TERMOSTATO			
80173GS1		ORING ASIENTO DISTRIBUCION			
80174GS1		ORING CUELLO DISTRIBUCION			
80175GS1		ORING TERMOSTATO - 1999/...			
179AM1		JUEGO DESMONTAJE TAPA DE CILINDRO			
80179VA1		JGO DESMONTAJE T. CIL. (S/JUNTA T.CIL.)			
168VA1		JGO DE JTAS P/MOTOR (SIN JUNTA T.CIL.)			
178AM1		JUEGO DE JTAS PARA MOTOR COMPLETO			

201AM1

CHEVROLET 400 / SUPER / CHEVY /
PICK-UP - MOTOR 194 / 230 / 250



180AM1

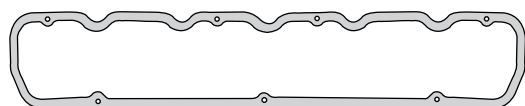

181CG1



183AM1



188AC6



189AC3

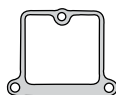

185AM1

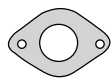

210AC6



184HH1

203AM1

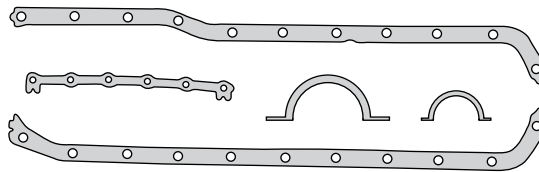

192CG2

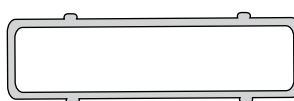

182CG1

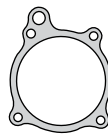

187AC3



209AC3

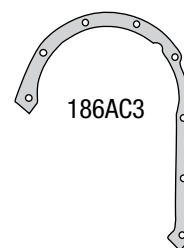

186AC3



213SA2



190AC3



191AC2

Nº Imperial	Nº Original	Descripción	Nº Imperial	Nº Original	Descripción
180AM1		JUNTA TAPA DE CILINDROS	191AC2		JUNTA TAPA BOMBA DE ACEITE
180AR1		JUNTA T.CIL. (COMPETICION 0,7mm)	191AD2		JUNTA TAPA BOMBA DE ACEITE
180AR2		JUNTA T.CIL. (COMPETICION 0,8mm)	209AC3		JUNTA BASE BOMBA DE ACEITE
180AR3		JUNTA T.CIL. (COMPETICION 1,0mm)	210AC6		JUNTA BASE CARBURADOR HOLLEY
181CG1		JUNTA TAPA DE VALVULAS	203AM1		JUEGO DESMONTAJE TAPA DE CILINDRO
181CG4		JUNTA TAPA DE VALVULAS (C Y G C/TELA)	205VA1		JUEGO DE JTAS P/MOTOR (S/JUNTA T.CIL.)
182CG1		JUNTA TAPA DE BOTADORES	201AM1		JUEGO DE JUNTAS P/MOTOR COMPLETO
192CG2		JUEGO DE JUNTAS PARA CARTER			
192CG5		JUEGO DE JTAS P/CARTER (C Y G C/TELA)			OTROS PRODUCTOS RELACIONADOS AL MOTOR
183AM1		JUNTA ADMISION Y ESCAPE			No se colocan en el juego de junta.
183HH1		JUNTA ADMISION Y ESCAPE (CHA/B/CHA)			
185AM1		JUNTA ENTREMULTIPLE DE ESCAPE	193VA1		JGO DE JTAS CARB. HOLLEY 1B C.CHICA
184HH1		JUNTA SALIDA DE ESCAPE	194VA1		JGO DE JTAS CARB. HOLLEY 1B C.GRANDE
186AC3		JUNTA TAPA DE DISTRIBUCION	195VA1		JUEGO DE JTAS CARB. ROCHESTER
186AD3		JUNTA TAPA DE DISTRIBUCION	196VA1		JUEGO DE JUNTAS CARBURADOR GALILEO
187AC3		JUNTA BOMBA DE AGUA	197VA1		JUEGO CARBURADOR HOLLEY 2 BOCA
187AD3		JUNTA BOMBA DE AGUA	213SA2		JUEGO EMPAQUETADURA DE BANCADA
188AC6		JUNTA TAPA TERMOSTATO			
188AD4		JUNTA TAPA TERMOSTATO			
189AC3		JUNTA BASE TERMOSTATO			
189AD3		JUNTA BASE TERMOSTATO			
190AC3		JUNTA BASE BOMBA DE NAFTA			

217AM1

CHEVROLET MONZA / VECTRA 2.0cc

MOTOR C2ONE

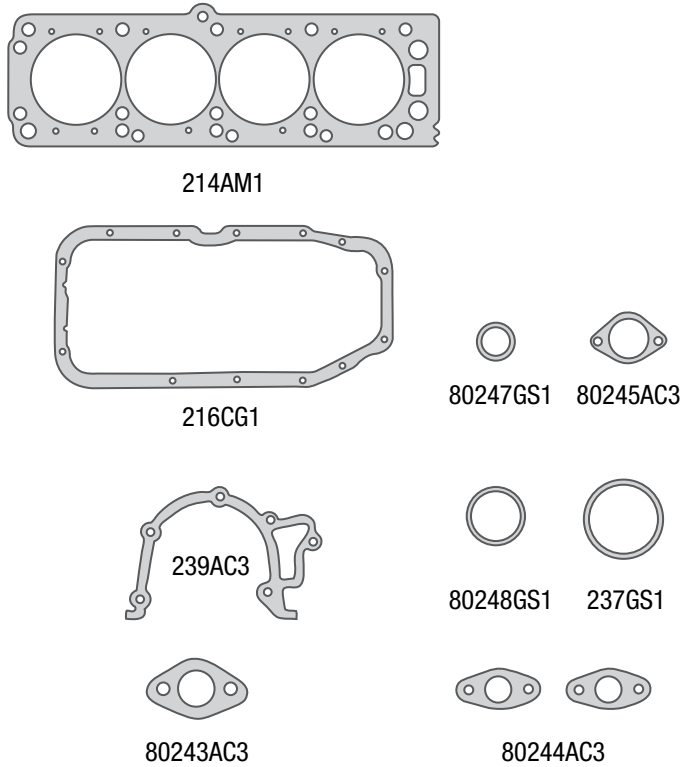
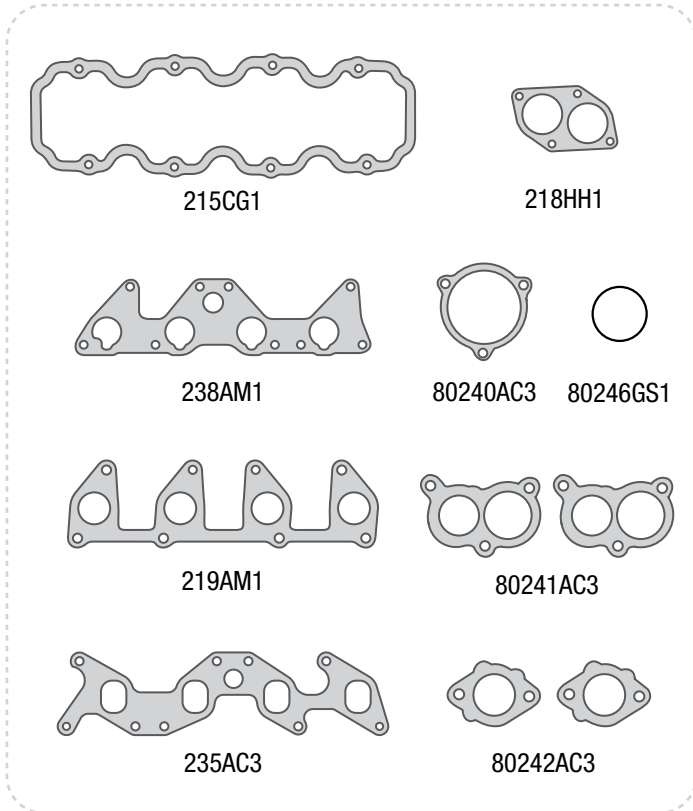
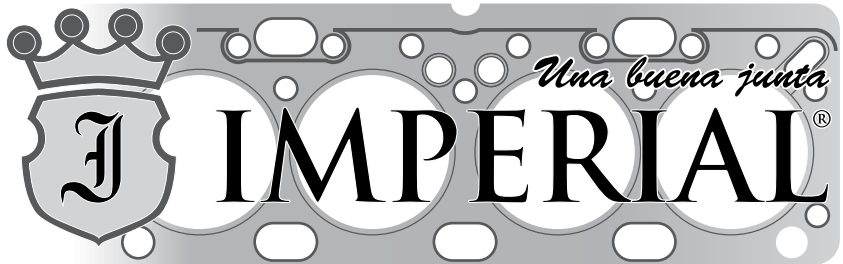

82049VA1

**Se incluye juego de ARANDELAS METÁLICAS*

Nº Imperial	Nº Original	Descripción	Nº Imperial	Nº Original	Descripción
214AM1		JUNTA TAPA DE CILINDROS			OTROS PRODUCTOS RELACIONADOS AL MOTOR
215CG1		JUNTA TAPA DE VALVULAS			No se colocan en el juego de junta.
216CG1		JUNTA PARA CARTER			
219AM1		JUNTA MULTIPLE DE ESCAPE	236VA1		JUEGO DE JUNTAS CARBURADOR BROSOL
219HH1		JTA MULTIPLE DE ESCAPE (CHA/B/CHA)			
235AC3		JUNTA MULTIPLE DE ADMISION			
238AM1		JTA MULTIPLE DE AD. MOTOR INYECCION			
218HH1		JUNTA SALIDA DE ESCAPE			
218HL1		JTA SALIDA DE ESC (LAM DE HOJALTA)			
239AC3		JTA FRENTE MOTOR - BOMBA DE ACEITE			
80240AC3		JUNTA TERMOSTATO			
80241AC3		JUNTA BASE CARBURADOR			
80242AC3		JUNTA BASE CARBURADOR			
80243AC3		JUNTA COMANDO			
80244AC3		JUNTA BOMBA DE NAFTA			
80245AC3		JUNTA TUBO BOMBA DE ACEITE			
80246GS1		ORING TERMOSTATO			
237GS1		ORING BOMBA DE AGUA			
80247GS1		ORING 15,5x1,7			
80248GS1		ORING 64x3			
80249VA1		JGO DESM T. CIL. (S/JTA T.CIL.)			
217AM1		JGO DE JTAS PARA MOTOR COMPLETO			

284AM1

CHEVROLET SILVERADO - CHEYENE

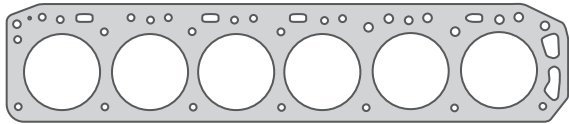
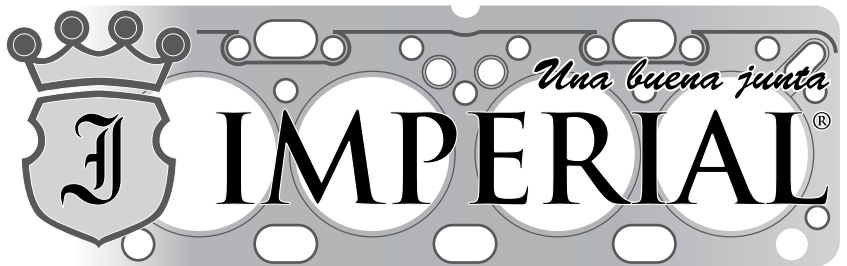

280AM1

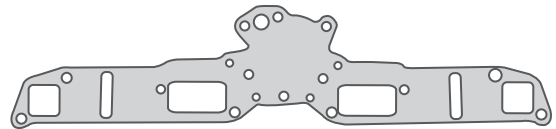

286HH1

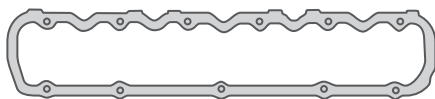

281CG1



190AC3



189AC3



188AC6



191AC2



282CG1

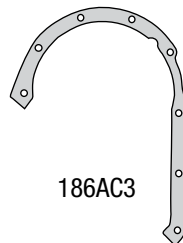

186AC3

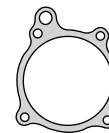

187AC3

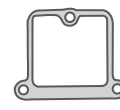

185AM1



184HH1

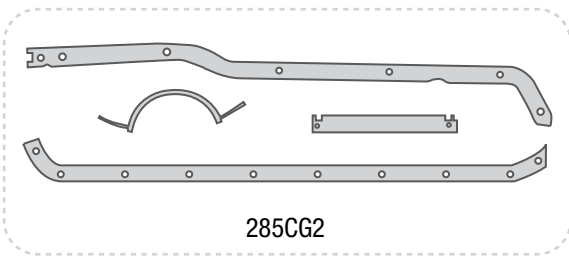

285CG2

N° Imperial	N° Original	Descripción	N° Imperial	N° Original	Descripción
280AM1		JUNTA TAPA DE CILINDROS			
281CG1		JUNTA TAPA DE VALVULAS			
282CG1		JUNTA TAPA DE BOTADORES			
285CG2		JUEGO DE JUNTAS PARA CARTER			
286HH1		JUNTA ADMISION Y ESCAPE			
184HH1		JUNTA SALIDA DE ESCAPE			
185AM1		JUNTA ENTREMULTIPLE DE ESCAPE			
186AC3		JUNTA TAPA DE DISTRIBUCION			
186AD3		JUNTA TAPA DE DISTRIBUCION			
187AC3		JUNTA BOMBA DE AGUA			
187AD3		JUNTA BOMBA DE AGUA			
188AC6		JUNTA TAPA TERMOSTATO			
188AD4		JUNTA TAPA TERMOSTATO			
189AC3		JUNTA BASE TERMOSTATO			
189AD3		JUNTA BASE TERMOSTATO			
190AC3		JUNTA BASE BOMBA DE NAFTA			
191AC2		JUNTA TAPA BOMBA DE ACEITE			
191AD2		JUNTA TAPA BOMBA DE ACEITE			
284AM1		JGO DE JUNTAS PARA MOTOR COMPLETO			

25109VA1

CHEVROLET ASTRA 2.0 / 2.2 16V

MOTOR ALEMAN

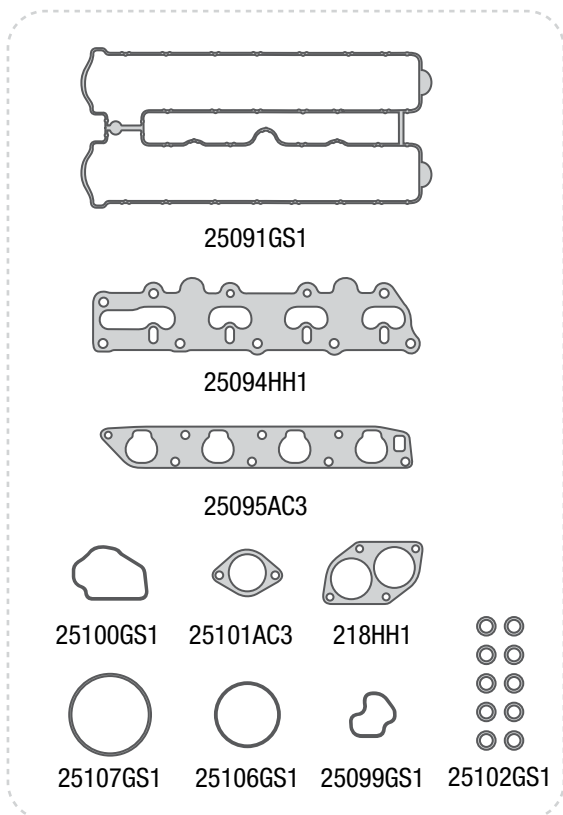

25108VA1

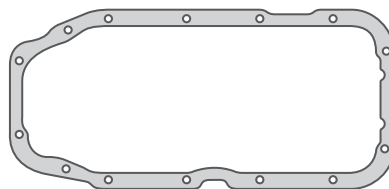

25092GS1

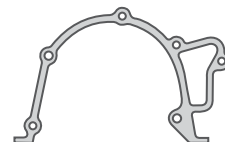

239AC3

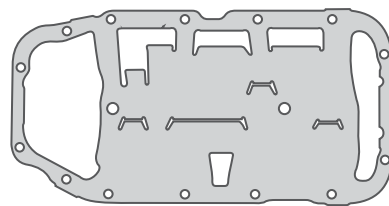

25092GS2

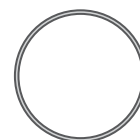

25105GS1



25103GS1

25104GS1

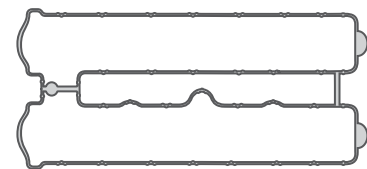

25091GS1

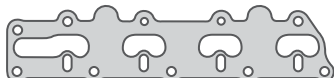

25094HH1



25095AC3



25100GS1



25101AC3



218HH1



25102GS1



25107GS1



25106GS1



25099GS1



25098AM1



237GS1



25101AC3

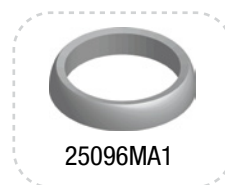

25096MA1

*Se incluye juego de ARANDELAS METÁLICAS

Nº Imperial	Nº Original	Descripción	Nº Imperial	Nº Original	Descripción
25091GS1		JUNTA TAPA DE VALVULAS			OTROS PRODUCTOS RELACIONADOS AL MOTOR
25092GS1		JUNTA PARA CARTER			No se colocan en el juego de junta.
25092GS2		JUNTA PARA CARTER (CON ROMPEOLAS)			
25094HH1		JUNTA MULTIPLE DE ESCAPE	25096MA1		JTA SAL DE ESC MALLA DE ACERO (ANILLO)
25095AC3		JUNTA MULTIPLE DE ADMISION			
239AC3		JTA FRENTA MOTOR - BOMBA DE ACEITE			
218HH1		JUNTA SALIDA DE ESCAPE			
218HL1		JTA SAL DE ESC. (LAMINAS DE HOJALTA)			
25098AM1		JUNTA PLACA ADMISION			
25101AC3		JUNTA NIVEL DE ACEITE			
237GS1		ORING BOMBA DE AGUA			
25099GS1		JUNTA TERMOSTATO			
25100GS1		JUNTA TERMOSTATO			
25102GS1		ORING 9x2			
25103GS1		ORING 16x2,5			
25104GS1		ORING 17,2x1,8			
25105GS1		ORING 94x3			
25106GS1		ORING 47,3x1,8			
25107GS1		ORING 69,6x1,80			
25108VA1		JGO DESMONTAJE T. CIL. (S/JUNTA T.CIL.)			
25109VA1		JGO DE JTAS P/MOTOR (SIN JUNTA T.CIL.)			

25118VA1

CHEVROLET ASTRA/VECTRA/ZAFIRA 2.0 - 2.2 16V -
MOTOR BRASILEIRO

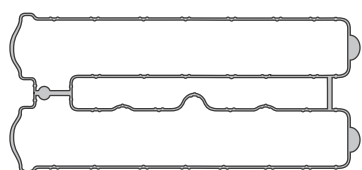
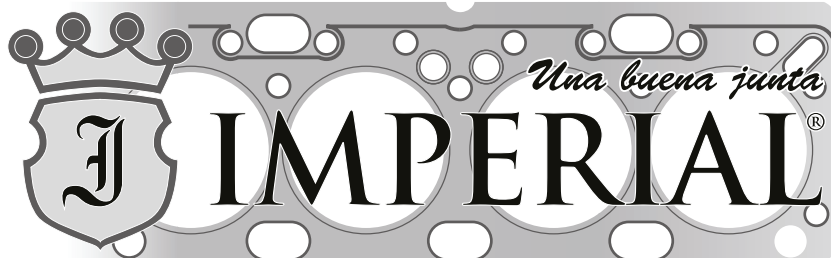

25091GS1

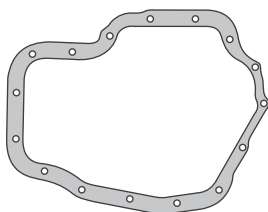

26053CG1



218HH1

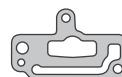

25098AM1

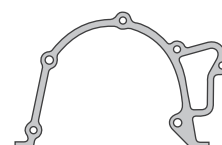

239AC3



95095AC3

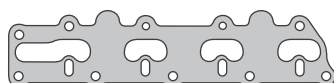

25094HH1



237GS1



25099GS1



25100GS1



25101AC3



1530

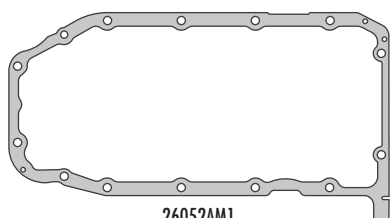

26052AM1



25111AC2



80243AC3



26081GS1



80246GS1



80241GS1



80248GS1



82039GS1



80174GS1



80247GS1

SE INCLUYE JUEGO DE ARANDELAS METALICAS

SINONIMO	N° ORIG	DESCRIPCIÓN	SINONIMO	N° ORIG	DESCRIPCIÓN
25091GS1		JUNTA TAPA DE VALVULAS	80243AC3		JUNTA COMANDO
26052AM1		JUNTA PARA CARTER	237GS1		ORING BOMBA DE AGUA
26052GS2		JUNTA PARA CARTER (GOMAMETAL)	25099GS1		JUNTA TERMOSTATO
26053CG1		JUNTA PARA CARTER INFERIOR	25100GS1		JUNTA TERMOSTATO
25094HH1		JUNTA MULTIPLE DE ESCAPE	80174GS1		ORING 15,5 X 2,6
25095AC3		JUNTA MULTIPLE DE ADMISION	80246GS1		ORING TERMOSTATO
239AC3		JTA FRENTA MOTOR - BOMBA DE ACEITE	80247GS1		ORING 15,5 X 1,7
218HH1		JUNTA SALIDA DE ESCAPE	80248GS1		ORING 64 X 3
218HL1		JTA SAL DE ESC (LAMINAS DE HOJALTA)	82039GS1		ORING 46,2 X 3,5
25098AM1		JUNTA PLACA ADMISION	82041GS1		ORING 52,4 X 2,6
25101AC3		JUNTA NIVEL DE ACEITE	1530		ORING 53,7 X 1,78
25111AC2		JUNTA	25118VA1		JGO DE JTAS P/MOTOR (SIN JUNTA T.CIL.)

25298VA1

CORSA / COMBO 1.7 DIESEL

MOTOR 4EE1/T

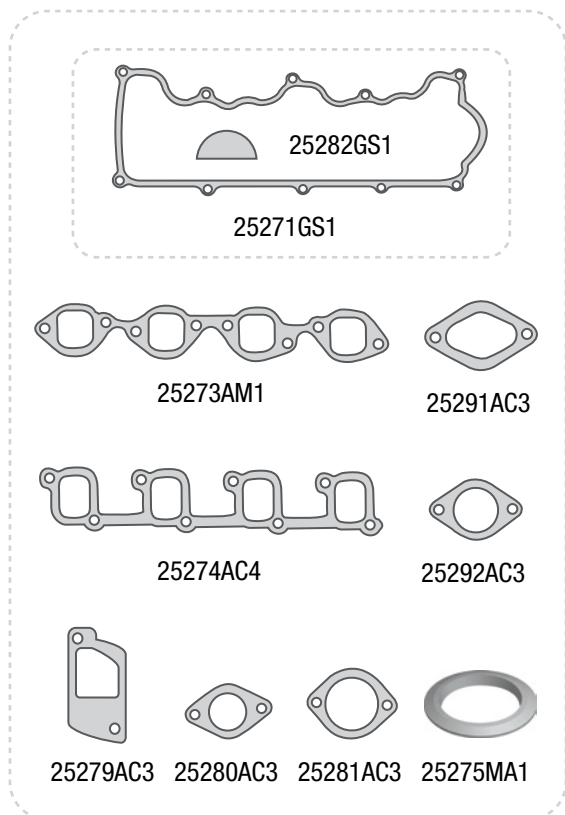

25297VA1

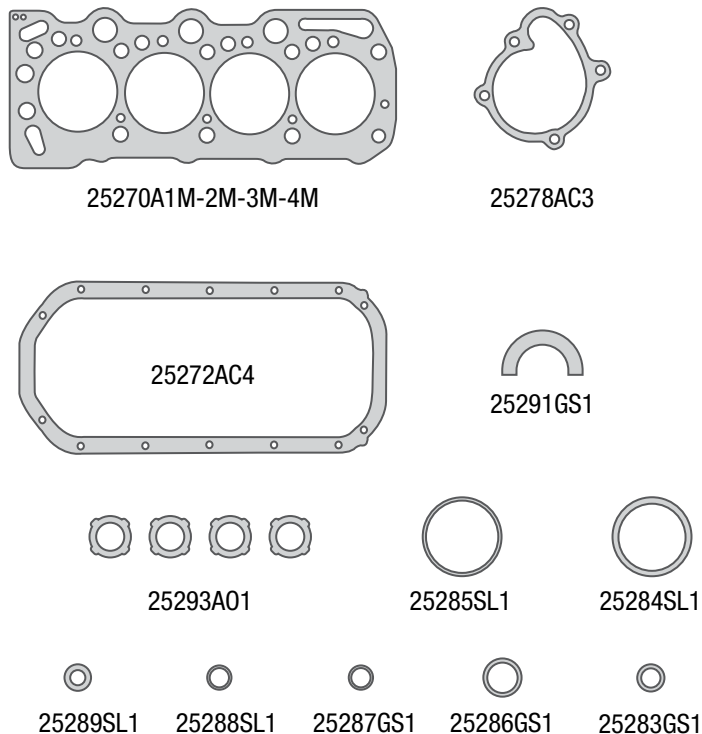

*Se incluye juego de ARANDELAS METÁLICAS

Nº Imperial	Nº Original	Descripción	Nº Imperial	Nº Original	Descripción
25270A1M		JUNTA TAPA DE CILINDROS	25293A01		ARANDELA PARALLAMA CHEV. 1.7 D
25271GS1		JUNTA TAPA DE VALVULAS	25297VA1		JGO DESM SIN T.C. C.CORSA 1.7D
25272AC4		JUNTA PARA CARTER	25298VA1		JGO SIN T.C. CHEVR. CORSA 1.7D
25273AM1		JUNTA MULTIPLE DE ESCAPE			
25274AC4		JUNTA MULTIPLE DE ADMISION			
25275MA1		JUNTA SALIDA DE ESCAPE - ANILLO			
25278AC3		JUNTA BOMBA DE AGUA			
25279AC3		JUNTA TAPA CAMARA DE AGUA			
25280AC3		JUNTA BASE TERMOSTATO			
25281AC3		JUNTA TAPA TERMOSTATO			
25291AC3		JUNTA FILTRO DE AIRE			
25292AC3		JUNTA INSPECCION TAPA CILINDRO			
25282GS1		CIERRE JUNTA TAPA DE VALVULAS			
25283GS1		BUJE BOMBA DE ACEITE 17x24x9			
25284SL1		ARANDELA 57x67x6			
25285SL1		ORING 64x2.5			
25286GS1		ORING 23x2			
25287GS1		ORING 17x2.2			
25288SL1		ORING 17x2.6			
25289SL1		ORING 10.8x2.3			
25291GS1		GUARN. CIERRE CHEV.CORSA 1.7D			
25291GS1		JUNTA CIERRE			

26068VA1

CHEVROLET VECTRA 2.0 / 2.2 8V MPFI

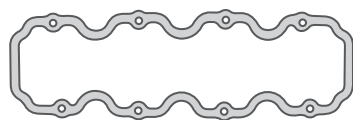

26051GS1

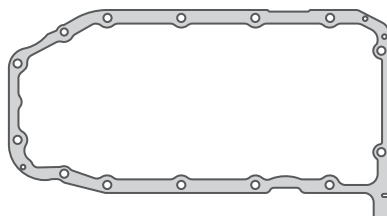

26052AM1

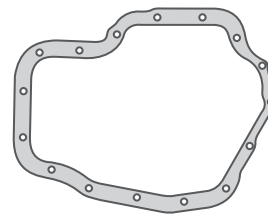

26053CG1



218HH1

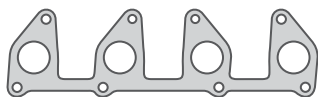

219AM1



26054AC4



238AM1

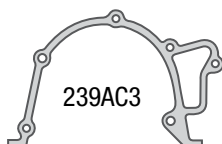

239AC3



237GS1



80241AC3



26057AC2



26058AC3



80243AC3



80245AC3



82039GS1



80246GS1



80240AC3



80241GS1



80248GS1



80174GS1



80247GS1



1530



26056AC3

*Se incluye juego de ARANDELAS METÁLICAS

Nº Imperial	Nº Original	Descripción	Nº Imperial	Nº Original	Descripción
26051GS1		JUNTA TAPA DE VALVULAS	80174GS1		ORING 15,5 x 2,6
26052AM1		JUNTA PARA CARTER	82039GS1		ORING 46,2x3,5
26052GS2		JUNTA PARA CARTER (GOMAMETAL)	82041GS1		ORING 52,4x2,6
26053CG1		JUNTA PARA CARTER INFERIOR	1530		ORING 53,7x1,78
219AM1		JUNTA MULTIPLE DE ESCAPE	26068VA1		JUEGO DE JTAS P/MOTOR (SIN JTA T.CIL.)
219HH1		JTA MULTIPLE DE ESCAPE (CHA/B/CHA)			
26054AC4		JUNTA MULTIPLE DE ADMISION (MPFI)			
238AM1		JUNTA MULTIPLE DE ADMISION (EFI)			
218HH1		JUNTA SALIDA DE ESCAPE			
218HL1		JTA SALIDA DE ESC (LAM. DE HOJALTA)			
237GS1		ORING BOMBA DE AGUA			
80240AC3		JUNTA TERMOSTATO			
80242AC3		JUNTA BASE CARBURADOR			
239AC3		JTA FRENTA MOTOR - BOMBA DE ACEITE			
80245AC3		JUNTA TUBO BOMBA DE ACEITE			
80243AC3		JUNTA COMANDO			
26058AC3		JUNTA BOMBA COMBUSTIBLE			
26056AC3		JUNTA			
80246GS1		ORING TERMOSTATO			
80247GS1		ORING 15,5x1,7			
80248GS1		ORING 64x3			
237GS1		ORING BOMBA DE AGUA			

26084VA1

CHEVROLET CORSA 1.6cc

8 VALVULAS C16SE - X16SZR

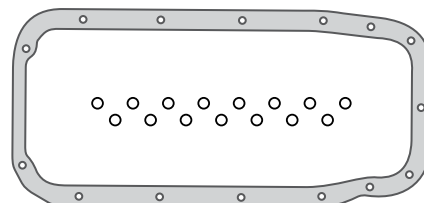
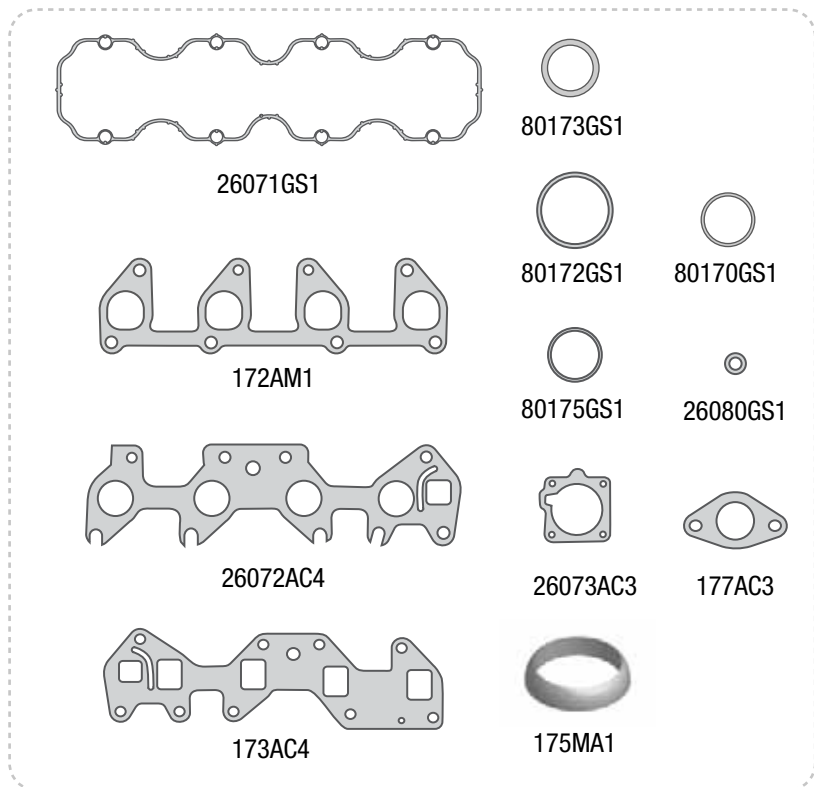

174CG1

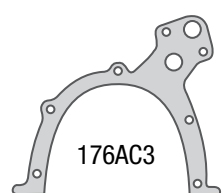

176AC3



80171GS1



26081GS1

26083VA1

Nº Imperial	Nº Original	Descripción	Nº Imperial	Nº Original	Descripción
26071GS1		JUNTA TAPA DE VÁLVULAS			
174CG1		JUNTA PARA CARTER			
26072AC4		JUNTA MÚLTIPLE ADMISIÓN			
173AC4		JUNTA MÚLTIPLE ADMISIÓN			
172AM1		JUNTA MÚLTIPLE DE ESCAPE			
176AC3		JUNTA FRENTE MOTOR BOMBA DE ACEITE			
177AC3		JUNTA SALIDA DE GASES			
26073AC3		JUNTA SOPORTE INYECCIÓN			
26080GS1		ORING 9,19 x 2,62			
26081GS1		JUNTA 59x39x3			
80170GS1		ORING TERMOSTATO			
80171GS1		ORING BOMBA DE AGUA			
80172GS1		ORING CARCAZA TERMOSTATO			
80173GS1		ORING ASIENTO DISTRIBUCIÓN			
80175GS1		ORING TERMOSTATO - 1999/...			
26083VA1		JUEGO DESMONTAJE T.CIL. (S/JTA T.CIL.)			
26084VA1		JUEGO DE JTAS P/MOTOR (SIN JTA T.CIL.)			

80202AM1

CHEVROLET C-10/C-20 - 1990 EN ADEL.

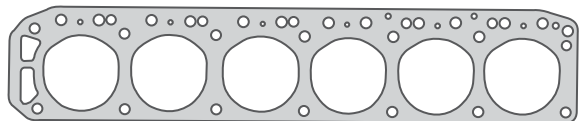

80180AM1



183AM1

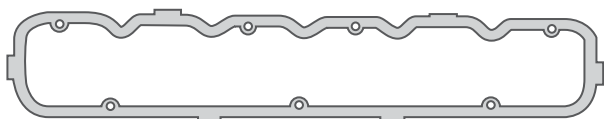

80181CG1

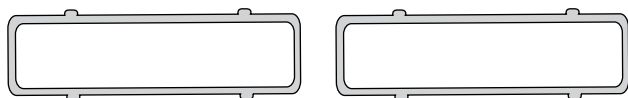

182CG1

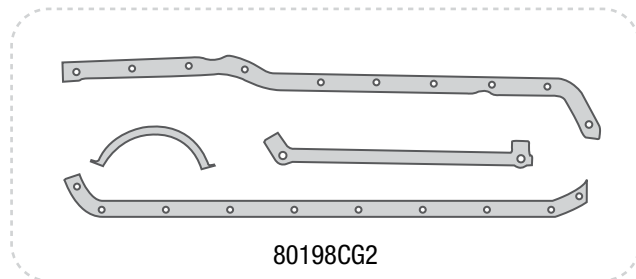

80198CG2



209AC3



184HH1

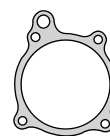

187AC3



189AC3

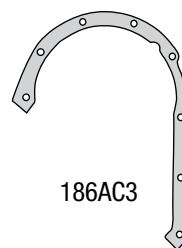

186AC3

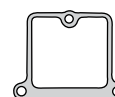

185AM1



191AC2



188AC6



190AC3

N° Imperial	N° Original	Descripción	N° Imperial	N° Original	Descripción
80180AM1		JUNTA TAPA DE CILINDROS			
80181CG1		JUNTA TAPA DE VALVULAS			
182CG1		JUNTA TAPA DE BOTADORES			
80198CG2		JUEGO DE JUNTAS PARA CARTER			
80198CG5		JGO DE JUNTAS P/CARTER (C Y G C/TELA)			
183AM1		JUNTA ADMISION Y ESCAPE			
183HH1		JUNTA ADMISION Y ESCAPE (CHA/B/CHA)			
185AM1		JUNTA ENTREMULTIPLE DE ESCAPE			
184HH1		JUNTA SALIDA DE ESCAPE			
186AC3		JUNTA TAPA DE DISTRIBUCION			
186AD3		JUNTA TAPA DE DISTRIBUCION			
187AC3		JUNTA BOMBA DE AGUA			
187AD3		JUNTA BOMBA DE AGUA			
188AC6		JUNTA TAPA TERMOSTATO			
188AD4		JUNTA TAPA TERMOSTATO			
189AC3		JUNTA BASE TERMOSTATO			
189AD3		JUNTA BASE TERMOSTATO			
190AC3		JUNTA BASE BOMBA DE NAFTA			
191AC2		JUNTA TAPA BOMBA DE ACEITE			
191AD2		JUNTA TAPA BOMBA DE ACEITE			
209AC3		JUNTA BASE BOMBA DE ACEITE			
80202AM1		JGO DE JUNTAS PARA MOTOR COMPLETO			